



ANTI-STATIC BRUSH FIELD UPGRADE (NMD-50)
(MODEL RL5000 X-SCALE ATM)

TDN 07100-00067 11/2006

CORPORATE HEADQUARTERS:

522 E. Railroad Street
Long Beach, MS 39560
Phone: (228) 868-1317
Fax: (228) 868-0437

**RMA (RETURN MATERIAL AUTHORIZATION)
RETURN ADDRESS:**

21405 Avenue "B"
Long Beach, MS 39560

COPYRIGHT NOTICE

© 2006 Delaware Capital Formation, Inc. All Rights Reserved. Triton Systems of Delaware Inc. is an operating company of Dover Electronics, Inc., a subsidiary of Dover Corporation (NYSE-DOV). DOVER, the DOVER logo and the Dover family of marks and TRITON, the TRITON logo and the Triton family of marks are registered trademarks of Delaware Capital Formation, Inc., a wholly owned subsidiary of Dover Corporation.

ANTI-STATIC BRUSH UPGRADE (NMD-50 DISENSING MECHANISM)

PURPOSE

This guide covers the steps for installing Anti-static brush hardware for an NMD-50 dispensing mechanism. Replacement of the bill tray assembly is also required. This procedure includes a list of all tools and hardware necessary for the conversion as well as the steps involved. The purpose of the kit is to eliminate static build-up in cold and dry environments. The result is better bill stacking in the bill tray.

SCOPE

This procedure applies to all service personnel involved in the process of maintaining or converting Triton ATMs.

REQUIRED PARTS AND TOOLS

TOOLS REQUIRED		
T-10 Torx 7/16" (11mm) Socket/Ratchet (w/extension)		
ANTI-STATIC BRUSH UPGRADE KITS (NMD-50) Business Hours Cabinet - P/N 06200-07050 Level 1 (Safe) Cabinet - P/N 06200-07000		
PARTS SUPPLIED		
PART NUMBER	DESCRIPTION	QUANTITY
04008-00040	Anti-Static Brush Kit (NMD-50) Kit contents: Brush (1), Bracket (1), Screw (4), Washer (4)	1
¹ 03011-01468	Bill Tray Chute (Top)	1
² 03011-01343	Bill Tray Chute (Top)	1
² 03011-01360	Bill Tray Chute (Bottom)	1
07100-00067	Installation Guide	1
¹ Included in upgrade kit 06200-07050 ² Included in upgrade kit 06200-07000		

INSTALLING THE ANTI-STATIC BRUSH KIT



① **Extend mechanism out fully.**

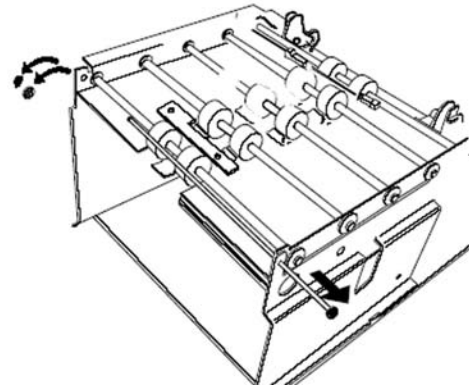

④ **Slide shaft out.**



② **Release side clips and remove cover.**

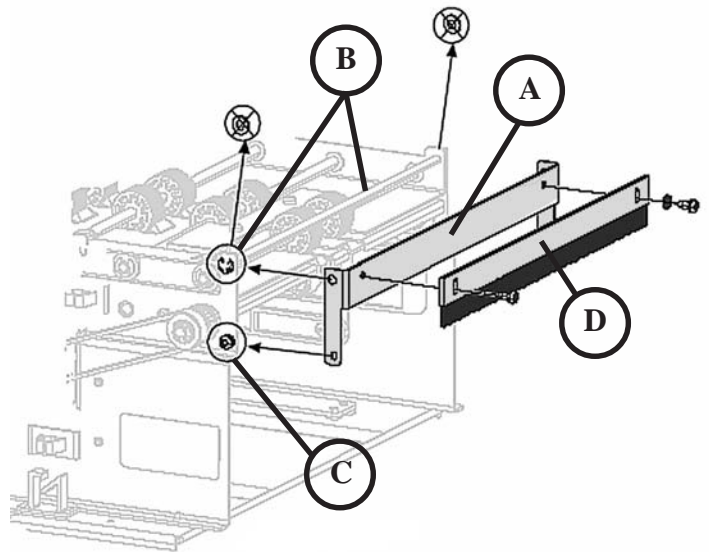

⑤ **Install Anti-static kit.**

A. Install brush bracket - Bracket mounts on outside of Note Transport sides.

B. Reinstall shaft - Shaft slides through holes in bracket. Secure with C-clip.

C. Secure lower legs of bracket with screws/washers.

D. Align brush to front of bracket and secure with screws/washers.

E. Reinstall cover

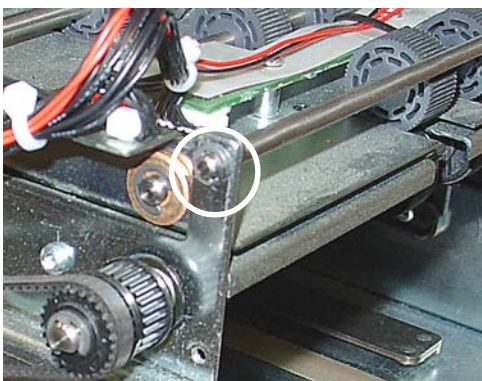

③ **Remove one (1) C-clip from the hinge shaft.**

INSTALLING THE BILL TRAY



Bill chute assemblies are installed/secured from the inside of door.

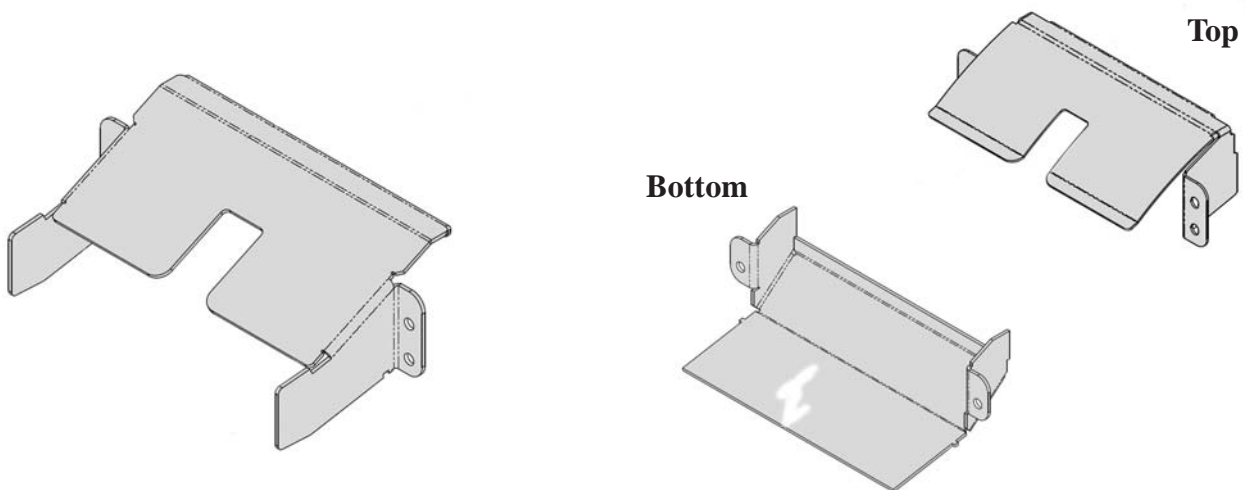

BUSINESS HOURS CABINET

Cabinet door - Remove existing *TOP* bill tray chute and replace with chute provided.

LEVEL 1 (SAFE) CABINET

Cabinet door - Remove existing bill tray chute assemblies (*Top/Bottom*) and replace with chutes provided.